

Relational Databases

alessio.brutti@unibz.it

For each of the following exercises, design the corresponding relational structure diagram (relational model). Draw tables, with the proper attributes, and relations between tables. For each table, primary and foreign keys must be highlighted.

Exercise 1

The university administration needs a database which handles data regarding students, exams and courses. Design a relational structure diagram satisfying the following constraints.

1. Students are identified by the student ID and have: name, surname, birth date, enrolment year and degree course.
2. Each course, which is identified by a name, is held in a specific language in the first or second semester and assigns a given number of credits.
3. For each course several exams take place. Students enrol through the university web site that delivers an enrolment number for confirmation. For each student, all attempts, with the related marks, are recorded.
4. Exams take place in a given date and time. One single professor is in charge of preparing, supervising and evaluating the exams. The professor name and surname are stored together with the text of the exam.

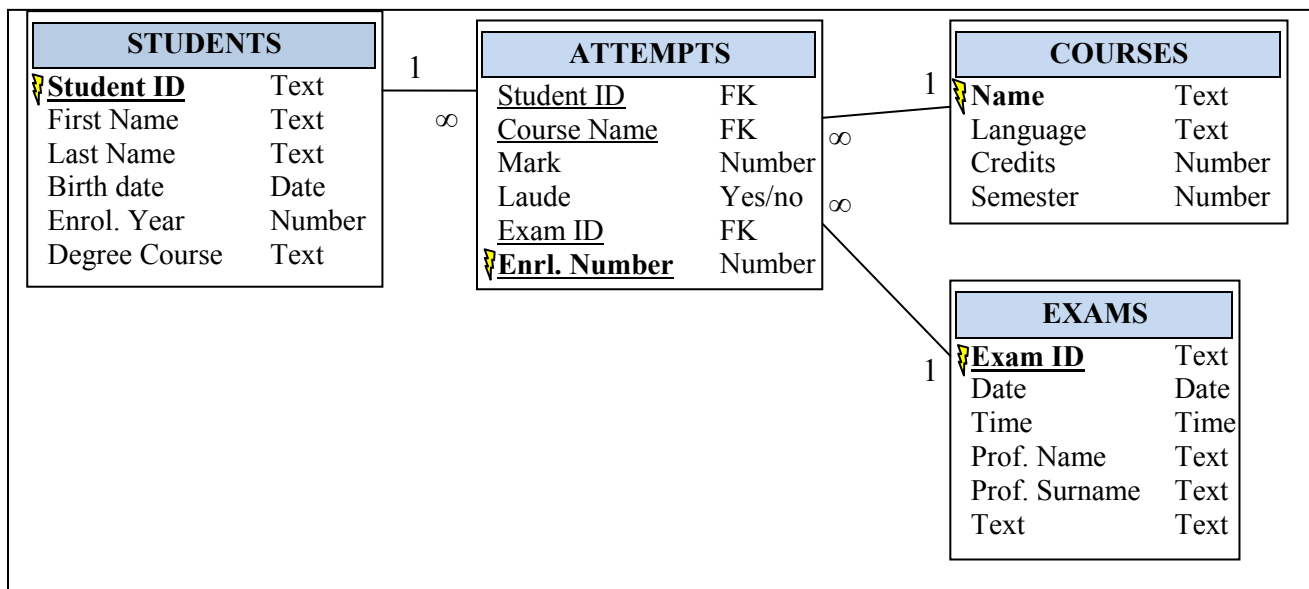

Figure 1 Database architecture for exercise 1

Exercise 2

A database needs to be developed for supporting a multiplex cinema centre. Design a relational structure diagram satisfying the following constraints.

1. The multiplex centre operates several cinema rooms. A room has a number, a room name, a number of seats. A room is identified by its number.
2. A film has a title and a code. The code identifies the film. The film has been produced by a production company in a specific year and is available in a specific language. Whenever a copy is available for parallel sessions, it has a different code.
3. A session takes place in a room on given date and time. Only one session can take place in a room at a given date and time (during a session only one film is shown). The same title could be shown in different sessions, possibly at the same date and time, and in different languages as well.
4. Reservations are made for a given number of seats and for a specific session. A person can make a reservation connecting to the multiplex website. The person provides name, e-mail address and phone number. For a given session, a reservation is uniquely identified by the assigned "Reservation Number". Tickets can be either printed at home or delivered at the ticket office.

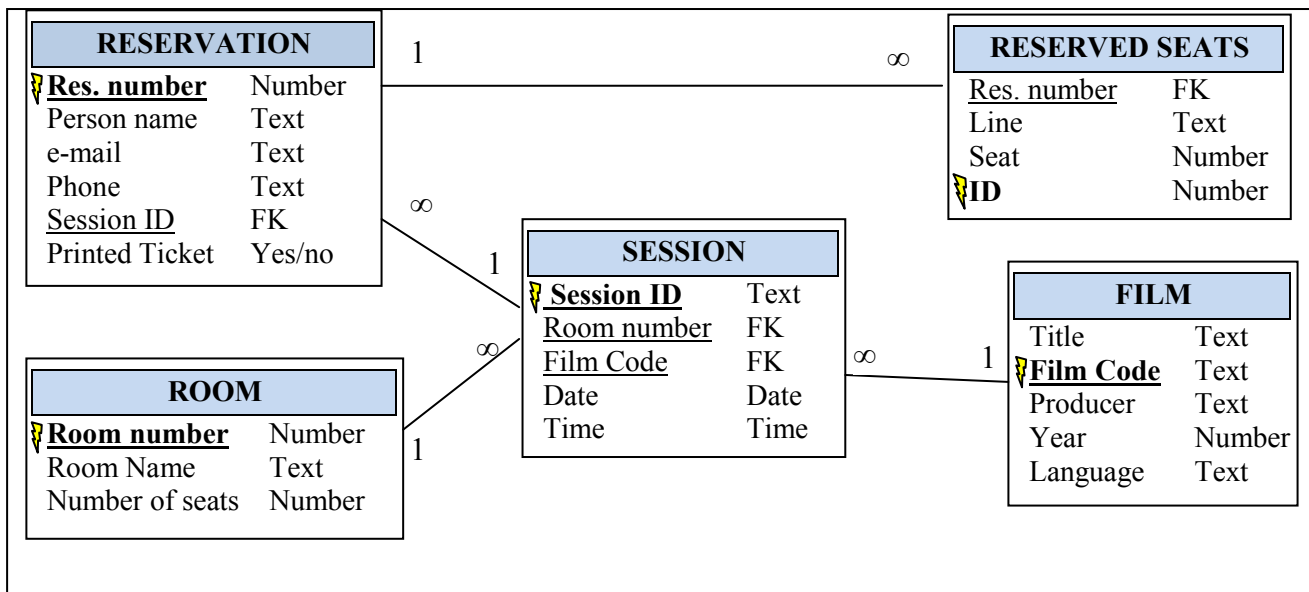

Figure 2 Database architecture for exercise 2

Exercise 3

A winery in the South-Tyrol region needs a database for storing information related to the wine productions. According to the database requirements described below, design a relational structure diagram.

1. The winery produces several different regional wines (Müller Thurgau, Lagrein, ...). A wine has a name, a specific production area and other descriptors like type (red, white, ...) and alcohol content. Each wine is uniquely identified by the name and the area of production.
2. The wine is obtained from grapes supplied by the members of the winery. The winery is a "Cooperative Society", thus the members are at the same time owners of the various vineyards.

3. Members are provided with a member ID, that uniquely identifies each of them. Each member has name, surname, address and vineyard references. The members may also have a specific role in the winery administration.
4. Yearly, at the end of the grape harvest, the winery collects grapes from the various members. The winery wants to keep track of the grape name, grape quantity, date of the harvest and the supplying member.
5. Finally, the winery has to record each produced wine with the production year, the used grapes and the supplier, the produced hectolitres and the cellarmaster. A product ID is assigned to each wine production. A member of the winery may be also a cellarmaster.

Figure 2 depicts a relational model that captures the above requirements.

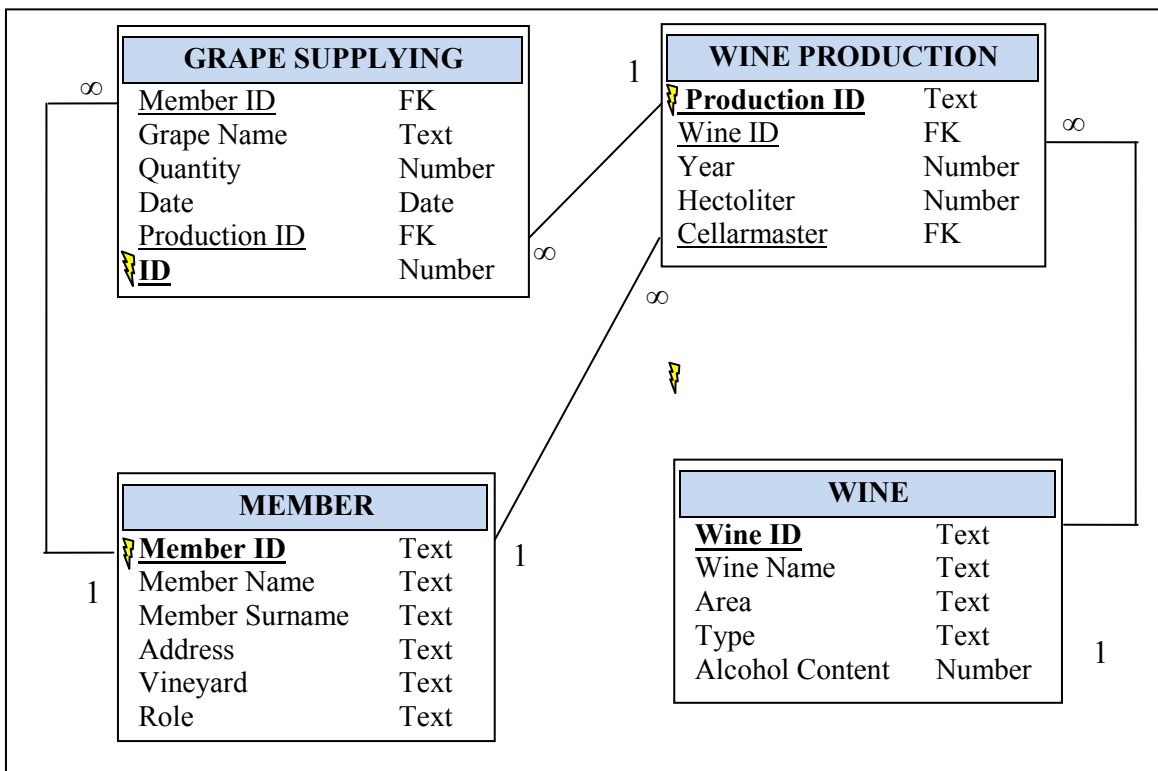

Figure 3 Relational model satisfying requirements of exercise 3

Exercise 4

We want to create a database in order to store the information related to our music library. Each DVD includes several songs which have authors and performers. On the other hand, a person may be either author or performer of many songs. The database requirements are listed below:

1. For each disk, we want to store the disk ID, the title and the year of production. Each disk ID is unique.
2. A song has a title and a number that indicates on which track it is recorded on one of the disks (identified by disk ID). For each disk, a song is uniquely identified by its track number and its disk ID.
3. For each person, either author or performer, we want to store the person ID, the name, and the nationality. Person IDs are unique.

- Each song has at least one author. There are different types of authorship, e.g., composer, text writer, or arranger. For each author of a song, we want to store the type of authorship.
- Each song has at least one performer. There are different instruments for a performer, e.g., voice, piano, violin. For each performer we want to store the instrument played during the recording.

Figure 3 depicts a relational model that captures the above requirements.

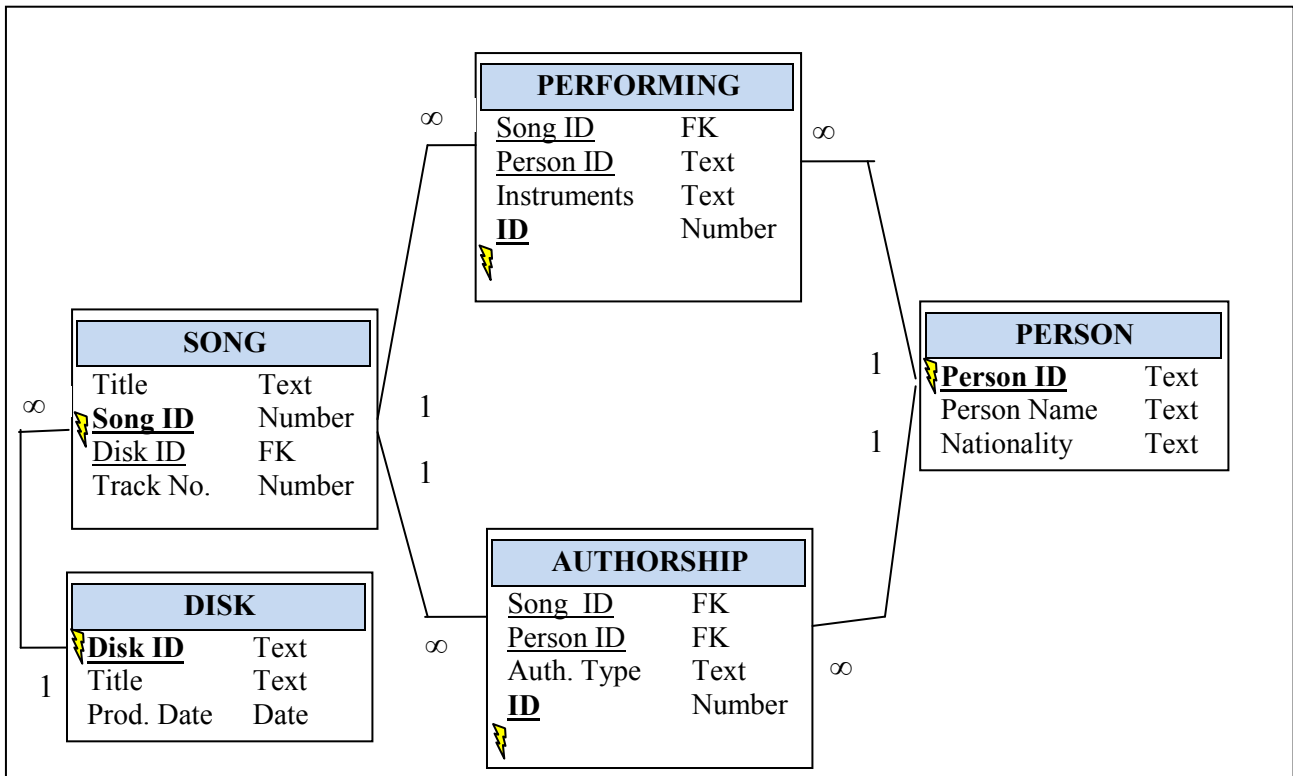

Figure 4 Relational model satisfying requirements of exercise 4

Exercise 5

A database needs to be developed in order to register users, contacts, messages, pictures of a “University Social Network”. Design the relational structure diagram that captures the requirements stated below.

- Through the “University Social Network” people can contact new and old friends and share with them common interests: opinions, web-links, pictures, video, etc. People participating in the social network have a personal account (user identifier, password, and email address). The user ID uniquely identifies a person.
- Users should be able to search on the network for a user, and then to establish a friendship. For each friendship the two user identifiers of who requested and who accepted the friendship are stored. The registration date and time are recorded too.
- Users activities on the network should be tracked: written opinions, messages sent, shared pictures and videos:
 - Message, and texts in general are registered with an identifier number, the publish date, and the type (message, news,..);

- Picture and video are registered with a code number, a short description of the object, the submission date, the type, and the typical attributes (quality, size, etc.).

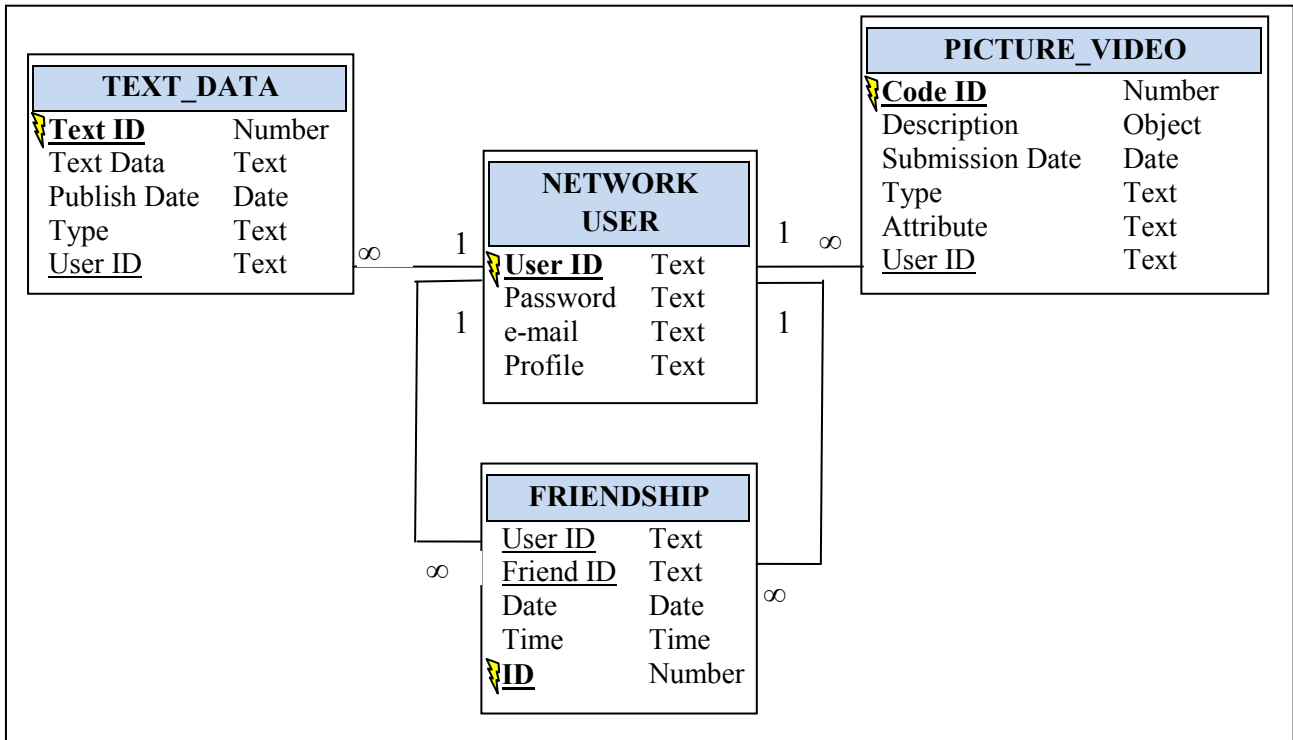

Figure 5 Database architecture for exercise 5